



Review Article

An Overview of The Hyphenated Separation Technology and its Application in the Pharmacy

Rutuja V. Pagare^{*1}, Dipti Phadtare²

¹Department of Pharmaceutical Quality Assurance, R. G. Sapkal College of Pharmacy, Anjaneri, Nashik

²Department of Pharmaceutical Chemistry, R.G Sapkal Institute of Pharmacy, Anjaneri, Nashik.

ARTICLE INFO

Received: 7 Sept. 2021

Revised: 15 Sept. 2021

Accepted: 28 Sept. 2021

Published: 30 Sept. 2021

Keywords:

Hyphenated technique,
GC-MS, LC-MS,
LC-NMR, CE-MS ,
Natural Product

DOI:

10.5281/zenodo.5483833

**Corresponding author:*

Rutuja Pagare*

Email:

rutujapagare1999@gmail.com

Address:

Department of
Pharmaceutical Quality
Assurance, R. G. Sapkal
College of Pharmacy,
Anjaneri, Nashik

ABSTRACT

Traditional analytical approaches, including high performance liquid chromatography (HPLC), gas chromatography (GC), and ultraviolet (UV) detection, cannot effectively address the emerging problems of species specificity and sensitivity analysis. A modern analytical technique called transferring is depend upon the traditional use of specific detection of molecules or elements in electrophoresis or chromatography. Currently, the most common methods for the estimation of trace elements include a combination of separation methods and more sensitive detection methods. Previously, this binding method was an additional combination of specialized offline sample preparation, separation and detection methods. Scripting technology is currently being developed by combining separation technology (chromatography) and spectroscopic detection technology online. The method written combines chromatographic and spectral methods to use both. Chromatography allows you to obtain pure or almost pure fractions of chemical components in a mixture. Spectroscopy uses standard spectra or libraries to obtain selective information for identification. This technology offers faster analysis times, higher automation, better throughput, better reproducibility, and less pollution. Since it is a closed system, it provides better binding selectivity and more information. The tremendous progress in written analytical methods over the last two decades has greatly expanded their application in the analysis of biomaterials, especially natural products. This article discusses the latest advances in various technologies such as GC-MS, LC-MS, LC-NMR, and CE-MS. As part of preliminary analysis of raw extracts or fractions from various sources, online isolation and discovery of natural substances, and chemical taxonomic studies.

INTRODUCTION

Hybrid technology: Several decades ago, Hirschfeld coined the term “hybridization,” meaning an online combination of a separation technique and one or more spectroscopic detection techniques. This method, developed from a combination of separation and spectroscopic

detection techniques, is now known as the hyphenation technique (Figure 1).

Chromatography: obtaining pure or almost pure fractions of the chemical composition in a mixture. Spectroscopy - generates additional information for identification with standard or library spectra.



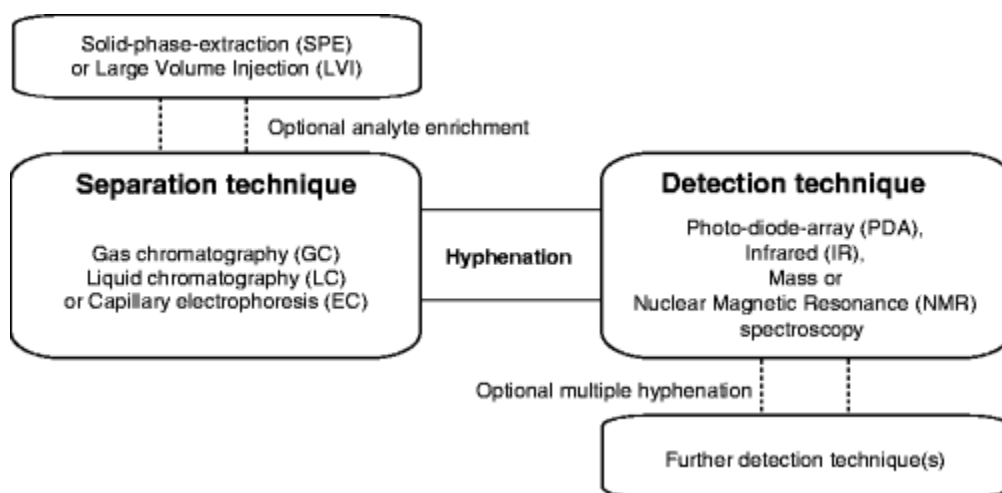

Figure 1: Hyphenated technique

A new dimension in writing technology that offers many important advantages in pharmaceutical analysis is multivariate chromatography. Several parameters were investigated, including the combination of GC, HPLC and CE systems under different conditions to analyze different types of samples [3]. Examples include size exclusion chromatography and RP-HPLC, EC, GC and LC. Since RP-HPLC and CE techniques can provide high resolution separation using orthogonal separation mechanisms, combining the two methods in 2D provides very high peak performance and very high resolution, especially for complex blending [4]

Advantages of hyphenated techniques [5]

1. Fast and accurate analysis
2. Process automation
3. High throughput
4. Excellent reproducibility
4. Reduced pollution through closed systems
5. Separation and quantification are performed simultaneously.

6. Provides superior separation and optional online spectroscopic data collection for LC or GC peaks of complex mixtures.

Types of Hyphenated Technique [6,7,8]:

GC-MS[2]:

When using MS as the recommended detection method and using one and three quadrupole mass spectrometers, ion attack and time of flight (TOF) are the most common instruments, while LC-MS and GC are the two most common methods. Today, GC / MS is a technology developed by linking GC and MS and is the first technology to be used for research and development purposes. The mass spectrum obtained with this hyphenation technique provides more structural information based on fragmentation analysis. GC / MS analysis may require polar compounds, especially those with many hydroxyl groups. The most popular derivatization method is the transfer of the analyte to a trimethylsilyl derivative.

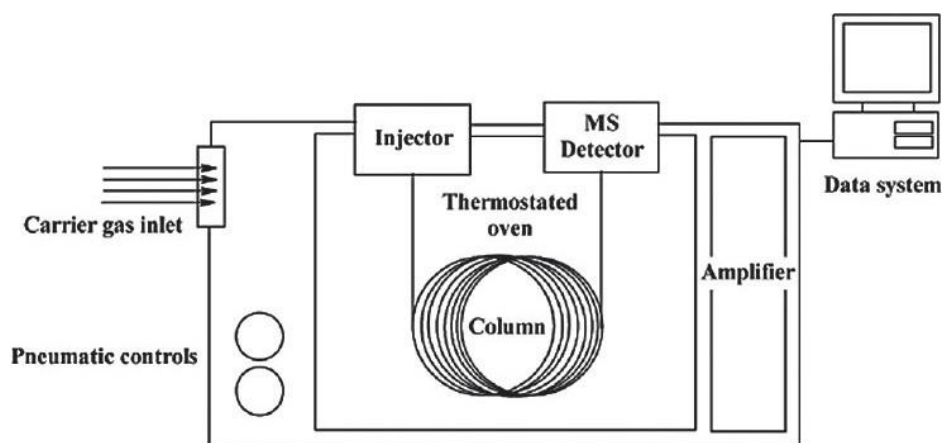

Figure.2: GC-MS

Instrumentation and Working:

When the analyte vaporized by the heated carrier gas passes through the GC column, it is simply separated from the column. The operator is also called the mobile phase. helium. The identified interaction of the analyte between the stationary and mobile phases which disturb the relationship. The separation of analytes also based on the column dimensions (length, diameter, film thickness), the type of carrier gas, the column temperature (gradient), and the characteristics of the stationary phase. The path of the sample through the column, differences in boiling points and other chemical separation factors of the mixture components. Due to differences in adsorption or separation between the stationary phase and the mobile phase, the elution and retention times of the components differ. The individual components of the mixture enter the MS via the interface. This is followed by ionization, mass spectrometry, and the estimation of the mass-to-charge ratio of the ions produced by each analyte using mass spectrometry. Interfaces are available in the form of effect splitters, beam / aperture splitters, and diaphragm splitters to connect the GC to the MS. The ionization process not only ionizes molecules, but also breaks them down into fragments and detects these fragments through electron collisions and chemical ionization. The analyte molecular ions produce a

spectrum of fingerprints that is different from that of other analytes. GC / MS is an essential tool in analytical chemistry. This technology is designed to accurately isolate, identify and provide information about the structure and composition of very small samples. The advantage of this method is that two different analytes can have the same mass spectrum, but since the retention times of the two analytes are different, GC-MS may be used as separation or analysis these types of analytes. Can you do this. Two ionization methods that are widely used in GCMS are electron bombardment & the alternative chemical ionization (CI) in either positive or negative modes ^[1]

Applications ^[10] :

1. Methods of Quantification of drinking water and wastewater contamination according to official US Environmental Protection Agency (EPA).
2. The quantitative determination of metabolites and drugs in urine is carried out for pharmacological and forensic purposes.
3. Identification of new unknown organic compounds at hazardous landfills and in reaction products using synthetic organic chemistry.
4. Used in the analysis of drugs, pesticides and herbicides.

LC-MS :

LC-MS stands for a combination of LC and mass spectrometry (MS) [Figure 3]. Individual samples in a column can be identified based on mass spectral data. Changeover valves help functionally combine the two technologies. A typical automated LC-MS system consists of an autosampler, an LC system, and a three-way dual transducer and mass spectrometer. The transducer typically acts as an automatic shutoff valve to drain unwanted portions of the LC system eluate

into the trash before the sample enters the MS. LC-MS combines the function of MS with chemical separation LC for selective detection, verification and confirmation of molecular identity. MS is one of the most selective and sensitive method of drug molecular analysis, which provides information on the molecular weight and fragmentation pattern of the analyzed molecules. The information obtained by MS is very important in determining the molecular identity of an analyte.

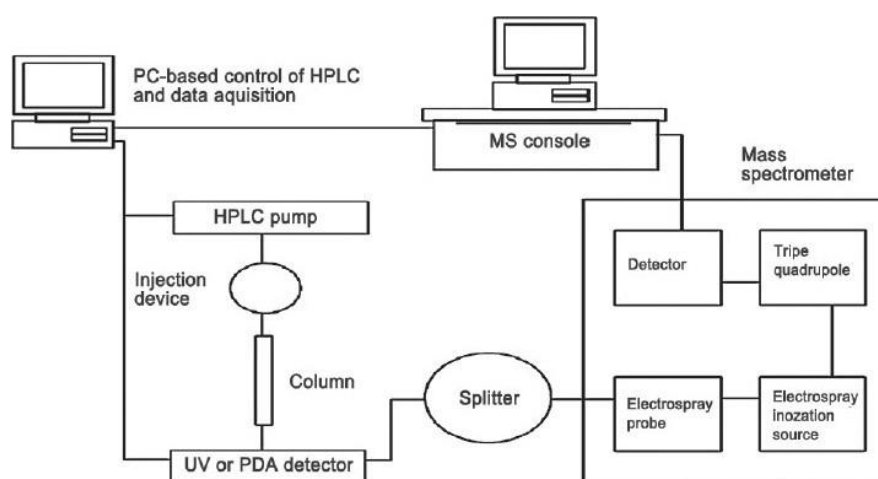

Figure 3:LC-MS

Instrumentation and working:

The LC-MS device can be associated with electrospray, particle beam, and thermal spray. Electrospray is the most popularly used interface. The syringe serves as a bridge between liquid chromatography and mass chromatography. However, independent radiators are flexible and practical. [9-12] Changeover valves help create a functional combination of the two technologies. A typical automated LC-MS system (Fig. 4) consists of a double three-way catalyst with the following characteristics:

1. Autosampler
2. LC system
3. Mass spectrometer.

The inverter typically acts as an automatic shutoff valve to divert unwanted portions of the eluate from the LC system into contaminants before the sample enters the MS. The ionization method used in LCMS is a weak ionization method that usually shows only molecular ions and a small number of fragment ions. Thus, the information on the structure of the compound obtained using a single LC-MS method is very weak. However, this problem is currently being solved by introducing tandem mass spectrometry (MS-MS), which provides fragments with collisional dissociation of the resulting molecular ions. The use of LC-MS-MS is growing rapidly. LC-MS combines the function of MS with chemical separation LC for selective detection and confirmation of molecular

identity. MS is one of the most selective and sensitive method of analysis of drug molecule , which provides information on the molecular weight and fragmentation pattern of the analyzed molecules. The information obtained using MS is very much important for the identification of analyte molecules ^[13, 14, 15]

Applications:

1. LC-MS for the detection of compounds from polycyclic (non-polar) aromatic compounds to peptides and proteins.
2. LC-MS for identification and purity of compounds.
3. Used to measure pesticides, herbicides and organic pollutants for environmental monitoring.
4. Provides information on the molecular weight and fragmentation pattern of analyte molecules.
5. This technique was used for proteomic analysis. ^[20]

LC-NMR^[6,8] :

In this technology, technological development allows the HPLC system and NMR to be directly

coupled in parallel, resulting in a new practical technology, HPLC-NMR or LCNMR, which has been widely known for more than 15 years. The first online HPLC-NMR experiment using superconducting magnets was reported in the early 1980s. However, the use of this scripted technique in analytical laboratories did not begin until the late 1990s. In fact, the benefits of closed-loop identification and separation circuits, along with the prospect of using all currently available 2D and 3D NMR technologies in a fully automated manner, have promoted the development of stopped-flow modes, such as time-delay modes. A typical LC-NMR experimental device is shown in Figure 4. LC-NMR experiments can be carried out in continuous flow mode and discontinuous flow mode. Using 500, 600 and 800 MHz instruments with ¹H, ¹³C, ²H, ¹⁹F and ³¹P probes can solve a wide range of biological analysis problems. In addition to NMR and HPLC instruments, the main prerequisites for online LC-NMR are the flow-through probe and the valve installed before the probe to record flow-through or stopped-flow NMR spectra.

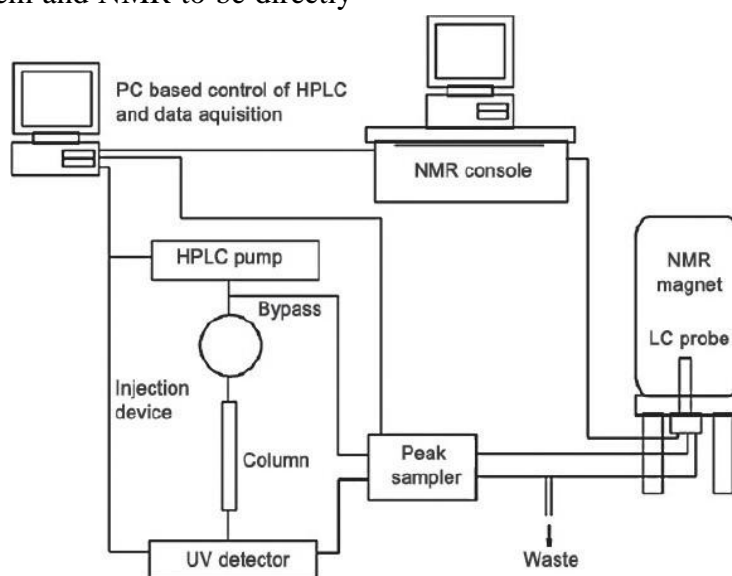

Figure 4: LC-NMR

Instrumentation and working:

LC-NMR is a sensitive technique because it uses a magnet with a strong magnetic field and a sensitive probe, and the NMR sensitivity can be increased by outdated technologies such as solvent removal techniques and suitable software for automated measurements. For multi-component analysis. The stronger the external magnetic field, the higher the sensitivity ^[16]. The increased sensitivity significantly shortens the measurement time. Compounds with complex spectra can be easily set on with a higher magnetic field, resulting in better signal resolution. ^[17]

Applications:

1. Provides information describing the structure of natural products.
2. Analysis of all kinds of complex mixtures, especially natural substances and drug-related metabolites in biological fluids.
3. This technology is used to detect pesticides, herbicides and organic pollutants for environmental monitoring.

CE-MS:

CE is an automatic separation technology that was introduced in the early 1990s. FE analysis is performed under the action of an electric field in a thin tube that can quickly separate hundreds of different compounds. The flexibility and various methods used for CE means that virtually any molecule can be isolated in this reliable way. It is commonly used to separate seeds by applying voltage to buffer-filled capillaries and to separate ions that move at different speeds depending on their size and charge when voltage is applied. A solution is considered a peak when it passes through the detector, and the area of each peak is proportional to its concentration, allowing for quantitative measurements^[21]. Testing includes purity measurement, test and trace measurement. When an EM detector is connected to a CE system to obtain live EM data for isolated connections, the resulting combination is called CE-MS [Figure 5].

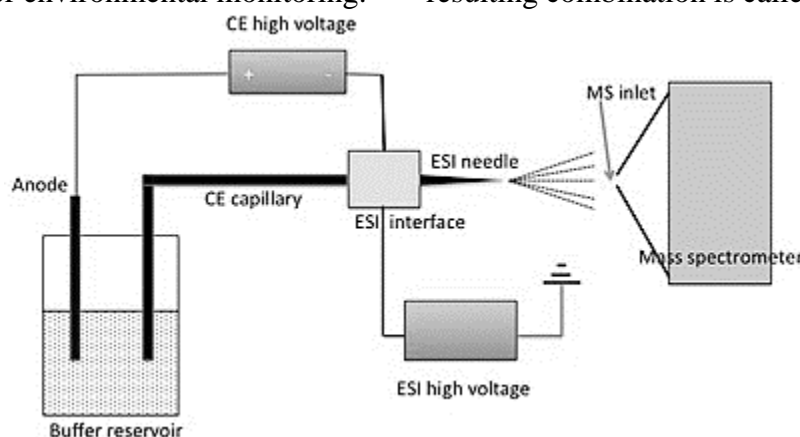

Figure 5: CE-MS

Instrumentation & working:

The detectors used for CE analysis are UV and DAD detectors, and the electrolytes used in this method are inorganic and non-volatile. This method has several disadvantages, including insufficient reproducibility, reproducibility and selectivity. This problem can be solved by using a buffer system that covers the inner walls of silica capillaries connected by a double layer. Very small

volumetric streams are transmitted via the interface to the MS. The ionization interface used is electrospray. Fast atomic bomb interface and ion spray ionizer. Mass spectrometry uses TOF detectors, ion traps and quadrupoles. The biggest advantage of a quadrupole detector is its sensitivity. ^[22]

Application

1. Bases and acids can be identified using non-aqueous CE-MS and non-aqueous CE-MS.
2. Analyze complex arabinooligosaccharides.
3. CE-MS is a drug and biomarker discovery tool.

Applications of Hyphenated Technique in Pharmacy [23,24,25,26]:

Figure 6 shows some examples of the application of methods for the analysis of natural materials.

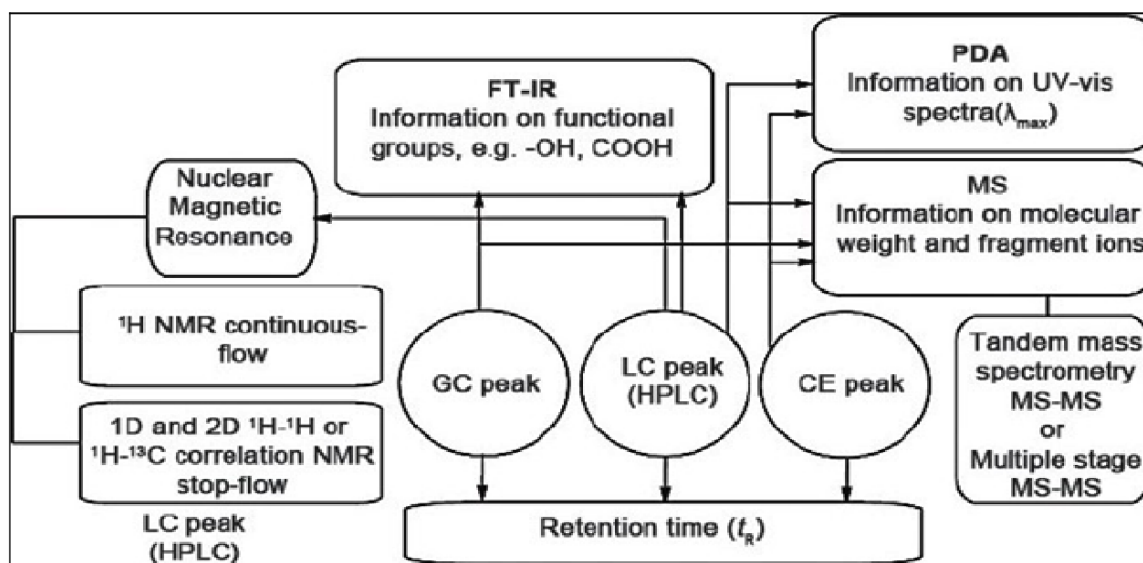

Figure 6. Applications of Hyphenated Techniques

Isolation and analysis of natural products:

Crude extracts of natural ingredients, which are very complex mixtures of many compounds, can be successfully analyzed using appropriate writing techniques. Among the various methods, LC-PDA and LCMS are the two most commonly used for the analysis of natural products. In addition to LC-NMR, various multiple binding techniques have recently been developed such as LC-PDA-NMRMS. If the ionization method is chosen correctly, LC-MS can be a very powerful and informative tool for the selection of crude plant extracts. The various types of LC-MS systems currently available allow the analysis of small non-polar compounds for large polar components such as oligosaccharides, proteins and tannins, which are present in natural product extracts [18]

Alkaloids

Alkaloids are a large group of secondary metabolites of plant, microbial or animal origin. Contains nitrogen. So far, different methods have been used to analyze different types of alkaloids. With the development and increasing availability of benchtop systems, GC / MS has become the method of choice for the analysis of several types of pyrrolizidine and quinolidine alkaloids. The alkaloids of cynolididine, an important class of legume alkaloids, have recently been analyzed by GC-MS. [25] Most of these alkaloids are thermally stable under GC conditions, they are quite volatile and can be analyzed without chemical modification. However, some hydroxylated pyrrolizidine alkaloids should be interpreted as trimethylsilyl derivatives. Ephedrine-type alkaloids in Chinese herbal medicine and nutritional supplements were analyzed by GC-MS and GC-FTIR methods.

Coumarins

Coumarins are the largest class 1 benzopyran derivatives, found primarily in higher plants. HPLC-PDA can be used to analyze a variety of phenolic compounds, including coumarins. This is due to the large number of chromophores present in these molecules. Measurement of coumarins with HPLC-PDA, in which the absorption spectrum is recorded on a PDA detector, provides useful information on molecular identity, including oxidation patterns. The retention time, together with the UV spectrum of each peak, can be considered a characteristic and can be easily used to detect known coumarins in crude extracts. The relationship between MS and LC-PDA provides additional structural information for online identification of individual coumarins in crude extracts. Several coumarins have been analyzed by atmospheric ionization along with other heterocyclic oxygen compounds found in the non-volatile residues of mandarin, sweet orange, bitter orange, bergamot, and grapefruit citrus oils (e.g. psoralen and polymethoxylated). LC-MS system with APCI probe in positive mode.^[19]

Carotenoids

Natural substances in this group include hydrocarbons (carotene) and their oxygen-rich derivatives (xanthophylls). LC-TLS has been successfully used for the quantitative determination of carotenoids from four phyto- and diatoxanthin, diatoxanthin and other carotenoids are also separated with higher sensitivity and selectivity than UV detection achieved by isocratic HPLC elution. This method monitors the conversion of diatoxanthin to diatoxanthin and changes in other carotenoids under various lighting conditions^[27]. LC-TLS is also a very sensitive method for measuring carotene in fish based on complement oil.^[28]

Essential oil and volatile components

GC / MS has established itself as an analytical tool, especially for the analysis of non-polar and

volatile natural materials such as mono- and sesquiterpenes ^[29] described how the direct expansion of GC-MS can measure approximately 130 volatiles in various herbs. They used the efficient GC-MS method using EI to isolate and assemble the de-esterified components of Chinese herbal medicine essential oils, Jilin ginseng, root and orange peel. *Pestasia Atlanticaba*. The main component of the monoterpenes of essential oils is oleoresin. *mutica* was recently analyzed by GC / MS in collaboration with an online database application.^[30]

Dereplication:

Differences between previously tested or processed natural product extracts can be demonstrated by reducing the mass collection of isolated isolates requiring more accurate assessment. Isolation of natural substances based on biological tests often results in compounds known to have limited or no chemical or pharmacological significance. Consequently, modern research on profitable natural products requires appropriate early differentiation methods for new natural products instead of known or already isolated natural products. The cloning strategy uses a combination of separation science, spectroscopic detection techniques, and online database searches. Thus, by combining HPLC with structurally advantageous spectroscopic detection methods (PDA, MS, NMR, etc.), extracts or crude fractions can be selected based on structural classification as well as biological activity. Biological testing and HPLC analysis using other detection methods were used to verify the effectiveness of the extract. Technologies such as HPLC combined with UV-photodiode detection (LC-DAD-UV) and mass spectrometry (LC-MS or LC-MS-MS) provide rich on-line analytical data for pre-isolated extracts. Combined HPLC with NMR (LC-NMR) is a powerful addition to LCUV-MS screening.

Chemotaxonomy:

Chemical classification, or chemical classification, is based on the principle that the presence of certain secondary metabolites is determined by various enzymes involved in the biosynthesis of these compounds. Thus, chemical profiling of these secondary metabolites, either through complete isolation and identification, or online isolation and identification using modern hyphenation techniques, can link and provide useful information for taxonomic or phylogenetic relationships between different species.

Chemical Fingerprinting and Quality Control of Herbal Medicine ^[30,31] :

In recent years, much attention has been paid to the use of hyphenation techniques in chemical fingerprint analysis for quality control and standardization of herbs, such as LC-MS, CE-MS, LC-NMR or LCNMR-MS. The fingerprint technique is often used to isolate the matrix profile of a sample in the context of drug analysis. This is often enough to show the source and its preparation. For medicinal herbs, the profile depends not only on the production process, but also on the quality of the herbal raw materials. Conforms to renowned standards for assembly of structures. The integrated MS database also helps to identify these connections. Thus, GC-MS, LC-MS and MS-MS fingerprint profiles were obtained from the active ingredients of various herbal extracts, and the information was stored in the form of an electronic database that could be used for routine comparisons. Analysis of the chemical profile of selected plant extracts for quality control. GC or LC data retention times and mass spectral data can be reproduced as long as the chromatographic and spectroscopic conditions remain constant. LC-NMR and LC-NMRMS are also used for this purpose. A simple protocol for chemical fingerprinting of ephedra using HPLC-PDA has recently been described. ^[33] Ephedra sinica (Ephedra family), also known as 'Ma huang', is

one of the oldest medicinal plants used in traditional herbal medicine. In Europe and the United States, E. with Sinica food supplement has become one of the top-selling weight loss and stamina products, used by over a million consumers.

Metabolomics:

The term "metabolomics" refers to the complete replacement of low molecular weight metabolites in living cells and is also used to describe the observed chemical profile or fingerprint of metabolites in tissues.^[34] Metabolites reflect the life history of an individual organism, including environmental factors such as age, soil type, moisture content, temperature, and stressors. Research involving detailed analysis of these metabolites is known as "metabolomics" and is a new area of research on natural products in the post-genomic era. The goal of metabolomics, like plant metabolomics, is to provide a better understanding of metabolism or other physiological phenotypes through global genome-related technologies. The profiling of off-target metabolites and the linking of these profiles to genotype or transcriptional profiles in metabolomics is considered an important topic.^[35]

CONCLUSION:

The technology developed by combining separation technology and online spectroscopic detection technology is called combined technology. The tremendous progress in written analytical methods over the past two decades has greatly expanded their application to the analysis of biomaterials, especially natural products. This article was recently developed using various methods such as GC-MS, LC-MS, LC-NMR, and CE-MS. Preliminary analysis of raw extracts or fractions from various natural sources, online isolation and detection of natural products, chemical taxonomic studies, chemical fingerprint



analysis, quality control of plant products, deduplication of natural products and related contexts are discussed. For example, research on

metabolomics. Emphasis is placed on written techniques, including LC as a cutting tool.

REFERENCES:

1. Guo X, Lankmayr E, Hyphenated Techniques in Gas Chromatography, Institute of Analytical Chemistry and Food Chemistry, Graz University of Technology, Austria, 14-19.
2. Wilson ID, Brinkman UA. Hyphenation and hypernation: the practice and prospects of multiple hyphenation. *J Chromatogr A* 2003; 1000: 325-56.
3. Bruins, A. P.; Covey, T. R.; Henion, J. D., Ion spray interface for combined liquidchromatography-atmospheric pressure ionization mass spectrometry. *Analytical Chemistry*. 1987, 59,2642-2646.
4. Nishino, I., Fujitomo, H. &Umeda, T. (2000) *J. Chromatogr. B: Biomedical Sciences and Applications*,749(1), 101.
5. Unni k, Hyphenated techniques breathing new life into the analytical instrument industry(online), 2004
6. Wolfender JL, Ndjoko K, Hostettmann K: LC/NMR in natural products chemistry. *Curr Org Chem* 1998; 2: 575-96.
7. L, George SA: Diode Array Detection in HPLC. New York: MercelDekker; 1993.
8. K: On-line use of NMR detection in separation chemistry. *J Chromatogr A* 1995; 703: 123-47.
9. Premstaller A, Oberacher H, Walcher W, Timperio A. M, Zolla L, Anal JP et al. *Chem* 2001; 73: 2390.
10. Wang YJ, Rudnick PA, Evans EL, Li J, Zhuang ZP, DeVoe DL, Anal C et al. *Chem* 2005; 77: 6549.
11. Barroso B, Lubda D, Bischoff R. *J Proteome Res* 2003; 2:633.
12. Luo QZ, Shen YF, Hixson KK, Zhao R, Yang F, Moore RJ, Mottaz HM, Smith RD. *Anal Chem* 2005; 77:5028.
13. Niessen WM, Tinke AP: Liquid chromatography-mass spectrometry, general principles and instrumentation. *J Chromatogr A* 1995; 703: 37-57.
14. Dugo P, Mondello L, Dugo L, Stancanelli R, Dugo G: LC-MS for the identification of oxygen heterocyclic compounds in citrus essential oils. *J Pharm Biomed Anal* 2000; 24: 147-54.
15. Wolfender JL, Rodriguez, S, Hostettmann K: Liquid chromatography coupled to mass spectrometry and nuclear magnetic resonance spectroscopy for the screening of plant constituents. *J Chromatogr A*, 1998; 794: 299-316.
16. Claridge TDW. "High-Resolution NMR Techniques in Organic Chemistry", Elsevier Science Ltd 1999; 228.
17. Takashi T, Masahiko O. Recent Progress in LCNMR Sumitomo Chemical Co., Ltd. Organic Synthesis Research Laboratory. Sumitomo Kagaku 2010; 2
18. Niessen WM. Liquid chromatography-Mass spectrometry. 2nd ed. New York: Dekker; 1999
19. Dugo P, Mondello L, Dugo L, Stancanelli R, Dugo G. LC-MS for the identification of oxygen heterocyclic compounds in citrus essential oils. *J Pharm Biomed Anal* 2000;24:147-54.
20. Lianghai H, Mingliang Y, Xiaogang J, Shun F, Hanfa Z. Advances in hyphenated analytical techniques for shotgun proteome



- and peptidome analysis—A review *Analytica Chimica Acta* 2007; 598:193–204
21. Dunayevskiy YM, Vouros P, Winter EA, Shippy GW, Carell T: Application of capillary electrophoresis-electrospray ionization spectrometry in the determination of molecular diversity. *Proc Natl Acad Sci* 1996; 93: 6152-7.
 22. Schmitt-Kopplin P, Frommberger M. Capillary electrophoresis- mass spectrometry: 15 years of developments and applications. *Electrophoresis* 2003; 24:3831-3867.
 23. Jinno K: Basics and applications of hyphenated-detection system in HPLC: Part I- Basics and applications in HPLC. *Pharm Stage* 2001; 1: 81-94.
 24. Jinno K: Basics and applications of hyphenated-detection system in HPLC: Part II-detection systems in HPLC. *Pharm Stage* 2001; 1: 74-80.
 25. Jinno K. Basics and applications of hyphenated-detection system in HPLC: Part III-hyphenated techniques in HPLC. *Pharm Stage* 2001; 1: 110-31.
 26. Kite GC, Veitch NC, Grayer RJ, and Simmonds MS: The use of hyphenated techniques in comparative phytochemical studies of legumes. *Biochem Syst Ecol* 2003; 31: 813-43.
 27. Bernet P, Blaser D, Berger S, Schar M. Development of a robust capillary electrophoresis-mass spectrometer interface with a floating sheath liquid feed. *Chimica* 2004;58:196-9.
 28. Luterotti S, Franko M, Bicanic D. Ultrasensitive determination of b-carotene in fish oil based supplementary drugs by HPLC-TLS. *J Pharm Biomed Anal* 1999;21:901-9.
 29. Chen Y, Li Z, Xue D, Qi L. Determination of volatile constituents of Chinese medicinal herbs by direct vaporization capillary gas chromatography mass-spectrometry. *Anal Chem.* 1987;59:744–8.
 30. Delazar A, Reid RG, Sarker SD. GC-MS analysis of essential oil of the oleoresin from *Pistacia atlantica* var *mutica*. *Chem Nat Compounds.* 2004;40:24–7.
 31. Cai Z, Lee FS, Wang XR, Yu WJ: A capsule review of recent studies on the application of mass spectrometry in the analysis of Chinese medicinal herbs. *J Mass Spectrom* 2002; 37: 1013-24
 32. Schaneberg BT, Crockett S, Bedir E, and Khan IA: The role of chemical fingerprinting: application to *Ephedra*. *Phytochemistry* 2003; 62: 911-8.
 33. Ducrey B, Wolfender JL, Marston A, Hostettmann K. Analysis of flavonol glycosides of thirteen *Epilobium* species (Onagraceae) by LC-UV and thermospray LC-MS. *Phytochemistry.* 1995;38:129–37.
 34. Ott KH, Aranibar N, Singh B, Stockton GW. Metabolomics classifies pathways affected by bioactive compounds. Artificial neural network classification of NMR spectra of plant extracts. *Phytochemistry.* 2003;62:971–85.
 35. Yamazaki M, Nakajima J, Yamanashi M, Sugiyama M, Makita Y, Springob K, et al. Metabolomics and differential gene expression in anthocyanin chemo-varietal forms of *Perilla frutescens*. *Phytochemistry.* 2003;62:987–95.

HOW TO CITE : Rutuja Pagare, An Overview of The Hyphenated Separation Technology and its Application in the Pharmacy, *Int. J. in Pharm. Sci.*, 2021, Vol 1, Issue 1, 1-11

